

YH02449

UC-NRLF



B 3 102 399

8
Physics
#4

McGILL UNIVERSITY

PAPERS FROM THE DEPARTMENT
OF
ENGINEERING.



No. 2.—HYDRAULIC LABORATORY, MCGILL UNIVERSITY.

BY

H. T. BOVEY, M.INST.C.E., LL.D.,

AND

J. T. FARMER, M.A.E.

[Read before Section G, British Association, Toronto, 1897.]

MONTREAL, 1898.

Read before Section G, British Association, Toronto, 1897.

Canadian Society of Civil Engineers.

INCORPORATED 1887.

ADVANCE PROOF—(*Subject to revision*)

N.B.—This Society, as a body, does not hold itself responsible for the facts and opinions stated in any of its publications.

HYDRAULIC LABORATORY, MCGILL UNIVERSITY.

BY HENRY T. BOVEY, M.INST.C.E., LL.D., etc., and
J. T. FARMER, MA.E.

(*To be read Thursday, May 5, 1898*)

General Description.—The laboratory is 39 feet in length and 31 feet in width. On the north side, near the centre, stands the Experimental Tank, having its base on a level with the bottom of a flume.

The flume, which is 5 feet wide and 3 feet 6 inches deep, runs from the tank and terminates in an adjustable weir. The water flowing through the flume may pass over or under the weir and may run to waste or may be made to pass into five large carefully calibrated tanks, 8 inches below the floor level and ranged in series on the south side of the Laboratory. The covering of the tanks is on the level and, indeed, forms part of the floor.

Over the easternmost of the tanks stands the Experimental Pump on a base formed of suitably designed carrying girders or trunks.

On the west side, at convenient points along the flume, are the following pieces of apparatus.—A 16 inch Pelton Wheel, with brake attachments, a Turbine Tester of special design and an Experimental Centrifugal Pump. Along the west wall is fitted up a Rife Hydraulic Ram with all the necessary pipes and tanks for experimental work. The pumps are driven from a line of 3½ inch steel shafting near and running parallel with the east side of the Laboratory. The shafting is operated by a 100 H. P. Mackintosh & Seymour high-speed horizontal engine, standing in an adjoining room. By means of an electromagnetic coupling, designed by Prof. Carus-Wilson, and connected with a switch conveniently placed near the Experimental Pump, the

main shaft can be almost instantaneously thrown in and out of gear and without sudden impact or shock, as the circular armature permits a partial rotation until the resistance is overcome. A 90 H. P. automatic recording transmission Dynamometer is placed on the shaft between the magnetic coupling and the nearest point at which power is transmitted. An 8 inch line of piping makes a complete circuit of the Laboratory near the ceiling. The several pumps and motors are connected with this circuit, and the movement of the water is controlled by suitably placed 8 inch straightway valves, branch tees, elbows, etc. By means of a short vertical length of 8 inch piping, terminating in a goose-neck, the pumps can be made to discharge into the top of the experimental tank from which the water passes into the flume, then into the large tanks, and is thus again available for supply. The whole of the water used in the Laboratory is drawn from the city high level reservoir, which gives at the base of the tank a pressure of more than 120 lbs. per square inch. The city service is connected with the 8 inch circuit, which can therefore, if desired, be made to act as a supply pipe to the turbines and other motors. Provision is also made for connecting the latter directly with the city service. The pumps and motors all discharge into the flume and the water then passes over the weir where the volume of discharge can be measured. If the volume is not too great it can be at once measured by passing the water into the large calibrated tanks.

The weir may be used the whole width of the flume without side contractions, but by means of suitable cheeks one or more side contractions can be introduced and the width of the weir diminished to any required extent, or the weir may be subdivided into two or more independent weirs. A large number of experiments have already been made to determine the coefficient of discharge with and without side contractions and with different depths of water over the weir lip. The results will be given as soon as the experiments have been completed. The water may be conveyed to any one of the five tanks through an iron channel provided with properly placed manholes, and the five tanks can all be connected together by means of a 10 inch pipe running along the bottom of a deep trough next the wall, and having the necessary valves and 6 inch branches communicating with the several tanks. The water may also be run to waste through this 10 inch pipe. In this channel and next the weir there is a flap-door with edges inclined at 45° to the vertical. The edges of the gap closed by the door are also inclined at 45° to the vertical, and the fit between the

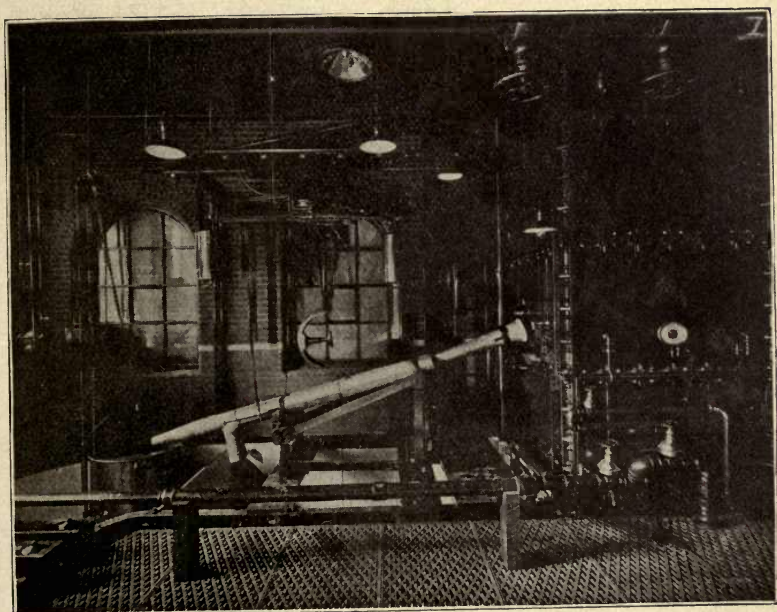

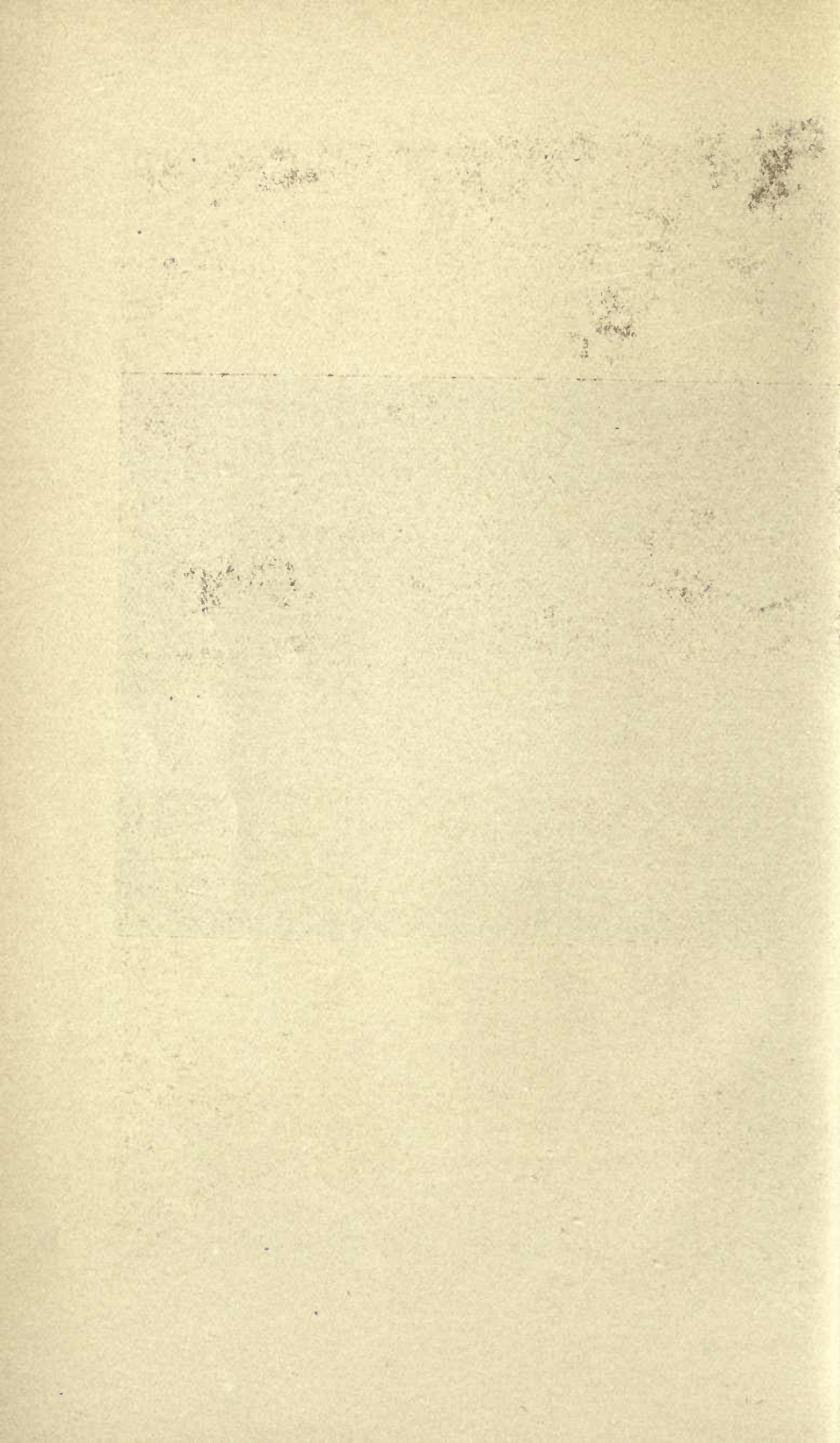

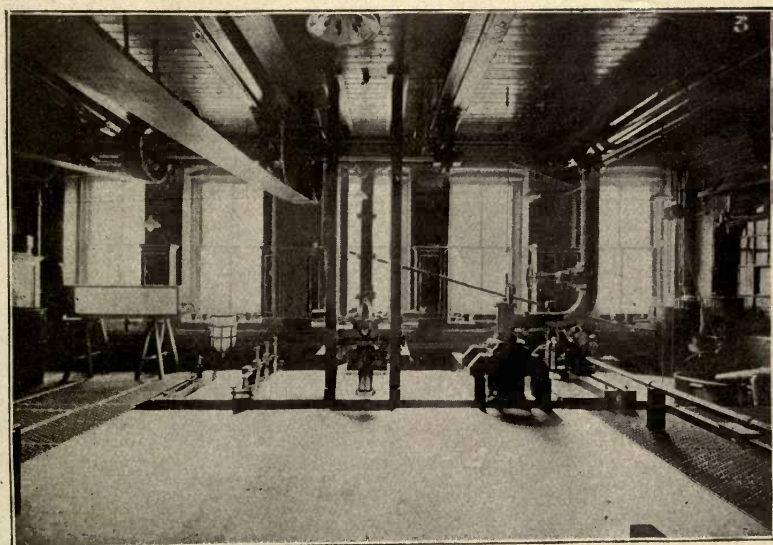
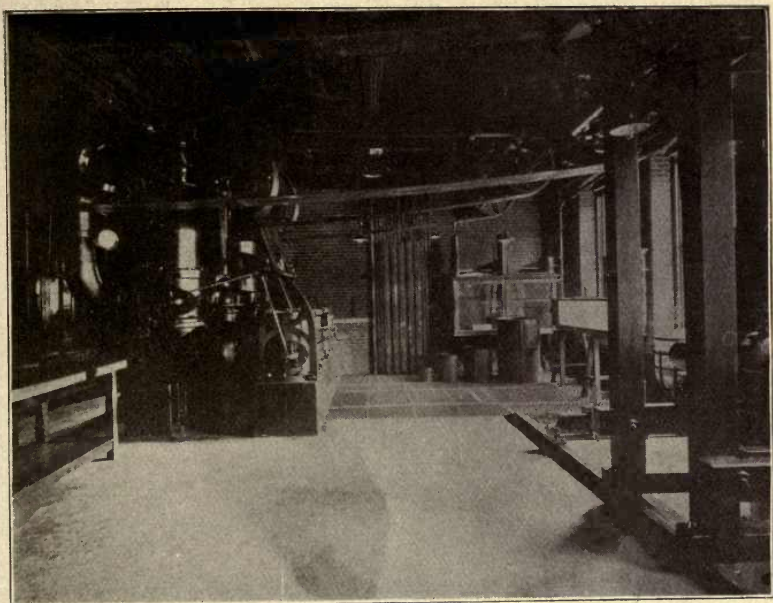

door and gap has been made as perfect as practicable. An india rubber cord is inserted in an endless groove running along the centre line of the edges, so that when the door is closed and pressed home it is absolutely water-tight. The door can be instantaneously opened and closed by means of a lever and a system of links acting as a toggle-joint, and each movement is recorded by an electrical chronograph. In any given experiment the door is opened and the water allowed to run to waste until the head over the weir lip is steady, when at a signal the door is instantaneously closed, when the water is conveyed by the channel into any or all of the tanks.

The stand-pipe for the fire-hose rises vertically at the back of the tank and extends to the full height of the building. At the base it is provided with a number of unions varying in size from 6 to 1 inch, and to these unions are attached the lines of piping for pipe-flow experiments. The position of the stand-pipe was selected so as to allow of straight lengths of more than 400 feet of pipe being used.

To secure a uniform pressure a Locke Regulator has been provided which responds, though slowly, to a variation in the pressure.

A special piece of apparatus for hose testing has been placed in the south-west corner of the Laboratory. It is connected by hydraulic piping with the Blake pressure pumps in the Testing Laboratory. A large number of tests have been made on the strength and on the longitudinal and circumferential extensibility of different varieties of hose, which in the great majority of cases was in lengths of 50 feet. The pressure, which often exceeded 800 lbs. per square inch, was directly indicated by a standard Crosby Gauge, while the time and pressure were also registered automatically by a recording gauge specially designed for this work.

Of the remaining apparatus the following may be briefly noticed :

A glass tank, 72 inches by 18 inches by 12 inches, with circular diaphragm chamber at one end. This serves to illustrate vortex ring motion and also, with the aid of glass tubes with flared ends and of different diameters, the critical velocity and other stream-line phenomena.

Inverted glass domes, with an orifice in the bottom, with which are demonstrated the phenomena of circular and spiral vortex motion, of the inversion of the vein, etc.

A series of very carefully made nozzles with a perfectly smooth bore, and having pressure gauge attachments at each end. Each nozzle is 36 inches in length between the gauge connections, and has a taper

corresponding to a diameter, varying from 3 inches to $2\frac{3}{4}$ inches in the largest to 3 inches to $\frac{1}{2}$ inch in the smallest.

A series of sixty hydrostatic gauges, each with a range of 20 lbs. and embracing pressures up to 140 lbs. per square inch. The gauges are graduated to tenths of a pound, and the range of every gauge is overlapped by the two consecutive gauges.

A mercury column, 27 feet in height, is fixed to the north wall near the experimental tank, and in addition to this there are several small portable mercury columns, which are used in the experiments for determining the resistance to flow in small pipes due to elbows, bends, convolutions, etc. These pipes are 13 in number, have a smooth bore and are $\frac{3}{8}$ inch in diameter.

The Laboratory is also supplied with a Venturi and other piston and rotary meters, a number of hook gauges, Darcy's improved Pitot tube, brass standard gallon, quart and litre measures with glass strikes, etc., etc.

Measuring Tanks.—There are several copper measures of capacities varying from 10 to 100 gallons. They have been carefully calibrated, and the calibrations are frequently checked. When in use they are placed upon a plane-table with adjustable feet so that a true level can be always maintained.

Each of the large tanks already referred to is 6 feet by 3 feet 6 inches by 9 feet deep, and discharges into the 10 inch header through a 6 inch straightway valve. Each tank is also connected with a separate vertical 4 inch brass pipe, in which the water freely rises and falls with the water in the tank. This forms the float chamber. These tanks have been carefully calibrated, and the contents can be readily measured to within the sixteenth of a gallon. The float is attached to a vertical $\frac{3}{16}$ inch brass rod with a pointer at the upper end, indicating on a brass plate the quantity of water in a tank. A fine cord, fastened to the top of the rod, rises vertically, passes around a frictionless pulley, and carries a constant weight at the end which counterbalances the rod, etc., keeps the cord taut, and so prevents the pointer from rubbing against the plate.

Experimental Tank.—The tank is of cast iron, is 28 feet in height, square in section, and has a sectional area of 25 square feet. Every care was taken to make the inside surfaces of the tank walls perfectly flush, and to this end the flanges, by which the several sections were bolted together, were placed on the outside. At first the water discharged from the tank was replaced by water admitted

into the top of the tank through a hose terminating in a rose submerged just below the surface. Although the utmost care had been taken in the design of this rose to reduce the eddy motion at efflux to a minimum, there was always an appreciable disturbance. The hose was therefore extended until the rose rested on the bottom of the tank, 8 feet below the orifice; with this arrangement a series of orifice-flow experiments were made, (the time in each case being the mean of that given by two stop-watches) and the values of the co-efficient of discharge are given in the following tables:

TRIANGULAR ORIFICE OF .05 SQ. IN. AREA AND REMAINING ORIFICES OF .0625 SQ. INS. AREA.

Head in feet.	Circular.		Equilateral triangle with horizontal base uppermost.		Square with vertical sides.		Rectangle with vertical sides equal to four times the width.		Rectangle with vertical sides equal to sixteen times the width.	
	T	S	T	S	T	S	T	S	T	S
1.	678	620	657	631	643	627	662	640	688	671
2.	618	613	646	623	631	621	643	629	655	657
4.	610	605	628	616	620	615	631	620	642	643
6.	637	601	628	613	615	612	627	616	634	636
8.	606	601	621	610	613	609	624	613	631	632
10.	604	600	618	608	612	608	621	613	629	629
12.	603	598	617	607	611	607	621	611	626	627
14.	602	598	617	607	610	606	620	610	623	625
16.	602	598	616	606	609	606	619	609	622	625
18.	601	597	615	605	607	605	618	608	622	623
20.	601	597	615	605	607	604	618	608	621	622

ORIFICES OF .197 SQ. IN. IN AREA.

Head in feet.	Circular.		Equilateral triangle with horizontal side uppermost.		Square with vertical sides.		Square with diagonal vertical.	Rectangle with vertical sides equal to four times the width.		Rectangle with vertical sides equal to one quarter the width.	Rectangle with vertical sides equal to sixteen times the width.	Rectangle with vertical sides equal to one sixteenth the width.
	T	S	T	S	T	S	S	T	S	S	S	S
1.	624	618	627	627	623	628	623	635	640	641	658	659
2.	616	611	620	621	613	621	619	626	633	632	646	646
4.	610	607	615	615	606	617	614	619	629	629	637	637
6.	607	605	613	613	604	614	612	616	625	627	634	633
8.	606	604	612	612	603	612	612	614	625	625	631	631
10.	606	604	611	611	602	610	611	612	624	623	630	629
12.	605	603	611	611	601	610	611	611	622	622	627	626
14.	604	603	610	610	600	610	609	611	622	621	624	625
16.	606	602	610	610	600	610	609	610	620	621	624	624
18.	605	602	610	610	600	610	609	609	620	620	623	623
20.	604	601	609	609	600	610	609	602	620	620	622	622

N.B.—In the above Tables T indicates a thickness of plate of .16 in., and S indicates that the orifice is sharp-edged.

The presence of the hose in the tank was not satisfactory, as it necessarily interfered with the stream-line motion, and therefore affected to a greater or less extent the values of the co-efficient of discharge. The hose was discarded, and the water is now admitted into a 3 inch chamber extending right across the bottom of the tank and containing perforations on the lower surface through which the water flows to the bottom and is there deflected upwards. Twelve inches above the bottom the water is made to pass through a baffle-plate perforated with $\frac{3}{8}$ in. holes, and 6 inches higher there is a second baffle-plate also perforated with $\frac{3}{8}$ in. holes. In order to equalize as much as possible the flow from all points, the pitch of the holes in the upper plate was determined by the projections on a horizontal plane of equal distances on a sphere of 10 ft. diam. with its centre at the centre of the orifice of discharge.

There are two outlet pipes for fast and slow discharge, and there are two inflow pipes, the one 3 ins. and the other $1\frac{1}{2}$ ins. in diameter. Each of these pipes is controlled by a stop-valve.

With this new arrangement, the time being taken by an electric chronograph, the following values for the co-efficient of discharge have been deduced for sharp-edged orifices :—

Head in feet.	Circular.	Square		Rectangular Ratio of sides 4 : 1.		Rectangular Ratio of sides 16 : 1.		Triangular.
		Sides vertical	Diagonals vertical.	Long side vertical.	Long side horizontal.	Long side vertical.	Long side horizontal.	
1.	.6199	.6267	.6276	.6419	.6430	.6633	.6644	.6359
2.	.6131	.6204	.6277	.6335	.6355	.6503	.6510	.6280
4.	.6081	.6162	.6177	.6281	.6293	.6409	.6415	.6228
6.	.6073	.6137	.6156	.6255	.6266	.6368	.6372	.6202
8.	.6056	.6127	.6138	.6234	.6252	.6342	.6346	.6189
10.	.6050	.6116	.6132	.6224	.6240	.6323	.6327	.6183
12.	.6040	.6109	.6123	.6217	.6230	.6311	.6314	.6177
14.	.6038	.6104	.6118	.6207	.6222	.6304	.6304	.6176
16.	.6032	.6099	.6113	.6203	.6215	.6301	.6298	.6171
18.	.6031	.6096	.6110	.6200	.6212	.6299	.6293	.6163
20.	.6029	.6094	.6108	.6198	.6210	.6291	.6285	.6160

The manner in which the head of water in the tank is defined is both simple and effective. A glass tube of $1\frac{1}{2}$ in. diam. is fixed to the tank by brackets and extends from the top to the bottom. On one side of the gauge there is a brass scale graduated from a zero point in the same horizontal plane as the centre of the orifice of discharge. A carrier with a horizontal wire passing in front of the gauge slides up and

down, and any required head is obtained by bringing the necessary scale graduation, the surface of the water in the gauge, the wire and its reflection in a mirror at the back of the gauge, into the same horizontal plane. There is a second indicator on the opposite side of the tank consisting of a float attached to an ordinary water-proof silk fishing line passing over a large light frictionless pulley and then vertically downwards in front of the tank. The cord is kept taut by a weight at the bottom, and carries a friction-tight pointer which can be easily and rapidly adjusted to indicate any required mark on a brass plate fixed in a convenient position on the tank face, so that the operator working the valves has it constantly under observation. As soon as the head of water in the tank has been determined by means of the glass gauge, the pointer is moved into position opposite the mark, and is kept there throughout the experiment. This obviates the necessity of constantly watching the level of the water in the gauge which, on account of the height of the tank, is often very inconvenient and troublesome. Occasionally, however, it is advisable to check the position of the pointer by observing the water-level in the gauge, as the cord-indicator is extremely sensitive, and the cord itself necessarily varies slightly in length, so that small errors might otherwise be introduced.

The head of water is brought to any required level by means of a three-way valve through which the water can either be admitted or may be allowed to escape. The valve is provided with a long vertical spindle, upon which handles are arranged at different points in such manner that one can be easily reached and operated from any position in the height of the tank. Close to the cord indicator and within the reach of the operator there is a $\frac{1}{4}$ -inch pipe with valve, which is useful for a fine adjustment when the inflow is only slightly in excess of the discharge.

The values of the co-efficient of discharge (c_d) were calculated from the usual formula.

$$c_d = \frac{Q}{At\sqrt{2gh}}$$

The area (A) of each orifice was practically the same and equivalent to the area of a circle of $\frac{1}{2}$ -inch diameter, or .19635 sq. inches.

The value of g (= 32.176) used in every case was that obtained for Montreal by Commandant Deforges in 1893.

At least two sets of measurements were made for each head, and the mean was adopted as correct if the results did not differ by more than 3 in 10,000.

The possible errors in the several factors of the above formula have been computed to be as follows :

Error in Q	For 20-ft. head.		For 1-ft. head.	
	20 in	100,000	20 in	100,000
" A	10	"	10	"
" t	5	"	1	"
" g	2	"	2	"
" h	1	"	20	"

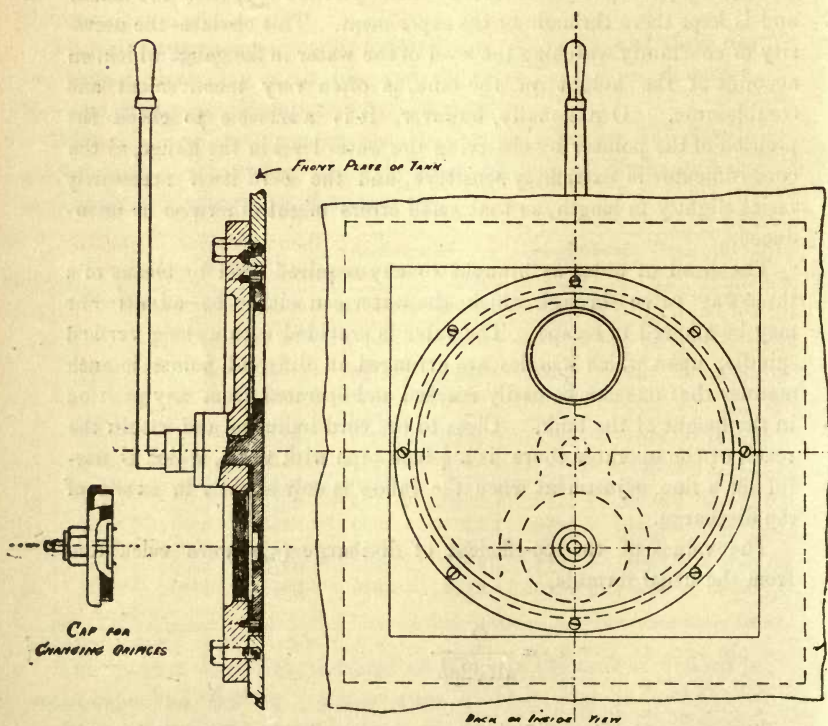

**CIRCULAR VALVE
OF EXPERIMENTAL TANK**

Designed by F. W. Bysemer...

Perhaps the most important feature of the tank is the valve arrangement. The valve is a gun-metal disc $\frac{3}{4}$ -in. in thickness and 24-ins. in diameter, fitted into a recess of the same dimensions in a cast iron cover plate, with gun metal bearing faces, forming a water-tight joint for the face of the disc. This cover plate or body is bolted to an opening in the front of the tank, and the inner faces of the cover plate or disc are flush with the inner surface of the tank.

In the disc and on opposite sides of the centre there are two screwed openings, the one 3-ins. and the other 7-ins. in diameter. By rotating the disc each opening can be made concentric with a screwed $7\frac{1}{2}$ -in. opening in the body of the valve. The disc is rotated by means of a spindle through its centre, passing through a gland in the front of the valve body and operated by a lever on the outside. Gunmetal bushes, with the required orifices, are screwed into the disc openings, and when screwed home have their inner surfaces flush with the valve surface, and therefore with the inside surface of the tank. By means of a simple device, these bushes can be readily removed and replaced by others without the loss of more than a pint of water. A cap with a central gland is screwed into the $7\frac{1}{2}$ -in. opening of the valve body and forms a practically water-tight cover. The valve is rotated so as to bring the bush opposite the opening, and it is then unscrewed by means of a special key projecting through the cap gland. The valve is now turned back until the opening is closed when the cap is unscrewed, the bush taken out and another put in its place. The cap is again screwed into position, the valve rotated until the openings in the disc and tank-side are concentric, when the bush is screwed home by the key.

The utmost care has been taken to form the orifices with the greatest possible accuracy. The orifices are worked in the discs approximately to the sizes required, and are then stamped out with hardened steel punches, the sizes of which have been determined with great exactness by means of Brown & Sharpe micrometers. The diameters of the orifices are also checked by a Rogers' comparator and a standard scale. In some cases a discrepancy has been found between the sizes of the die and its orifice, but the size obtained for the orifice is the one which has been invariably used in the calculations.

A gun metal bush or shell, screwed into each of the two openings in the main disc, carries a series of orifice plates. The larger bush takes plates with openings up to 4-ins. in diameter, and the smaller bush takes plates with openings up to $1\frac{3}{4}$ -in. in diameter. The plates are provided with a shouldered edge which fits against the correspond-

ing rim of the bush and are screwed with the orifice in any required position by means of an annular screwed ring fitting the interior surface of the bushing. The orifice plates are gun metal discs, $4\frac{1}{2}$ -ins. in diameter by $\frac{1}{4}$ -in. thick for the large bush and 2-ins. in diameter by $\frac{1}{8}$ -in. thick for the small bush.

Each of the larger orifices, from 4-ins. to 6-ins. diameter, is made in a separate bush which fits the 7-in. opening, and any of which can be easily taken out and replaced.

In "co-efficient of discharge" experiments, the water, on leaving the orifice, passes either to waste or to the measuring tank, through a bifurcated galvanized iron tubing, supported in a pivoted frame. The water is first run to waste through one of the branches until a steady head has been obtained, and the frame is then rapidly swung through a small angle by means of a lever, when the water passes through the other branch to the tank. As soon as the tank is sufficiently full, the frame is swung back and the water again runs to waste. In the forward and return movements, the lever makes and breaks an electric contact, the interval of time occupied by an experiment being registered by a chronograph.

In "co-efficient of velocity" experiments, the position of the jet from an orifice is defined by vertical measurements from a straight-edge, supported horizontally above the jet by a bracket on the tank face at one end and at the other on a bearing, which admits of a vertical adjustment.

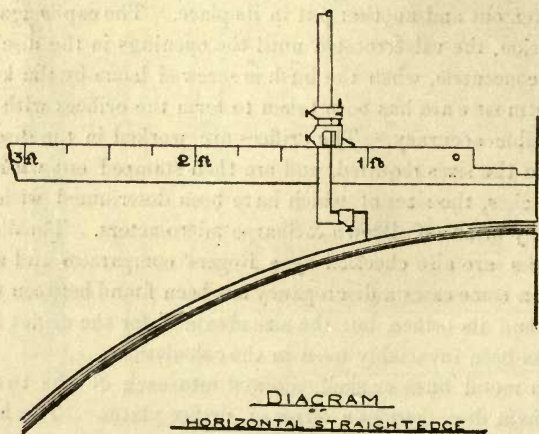

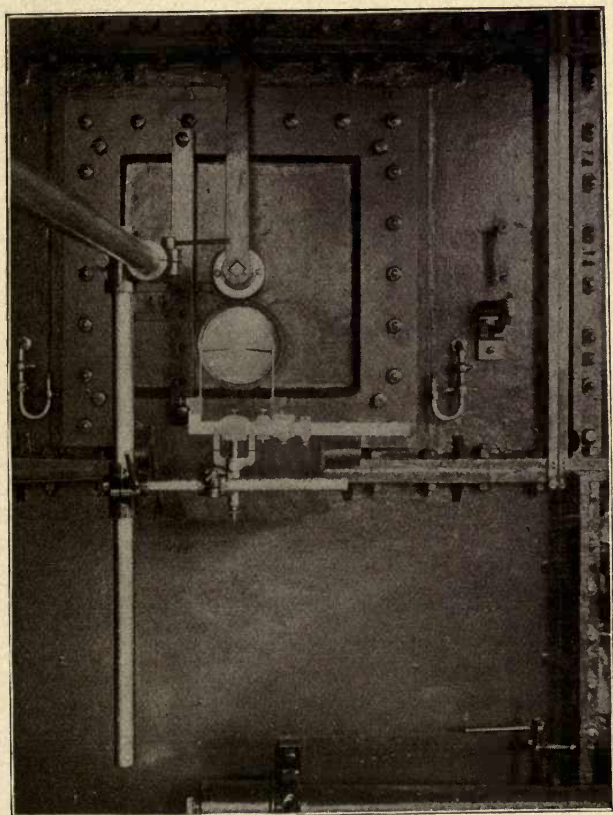

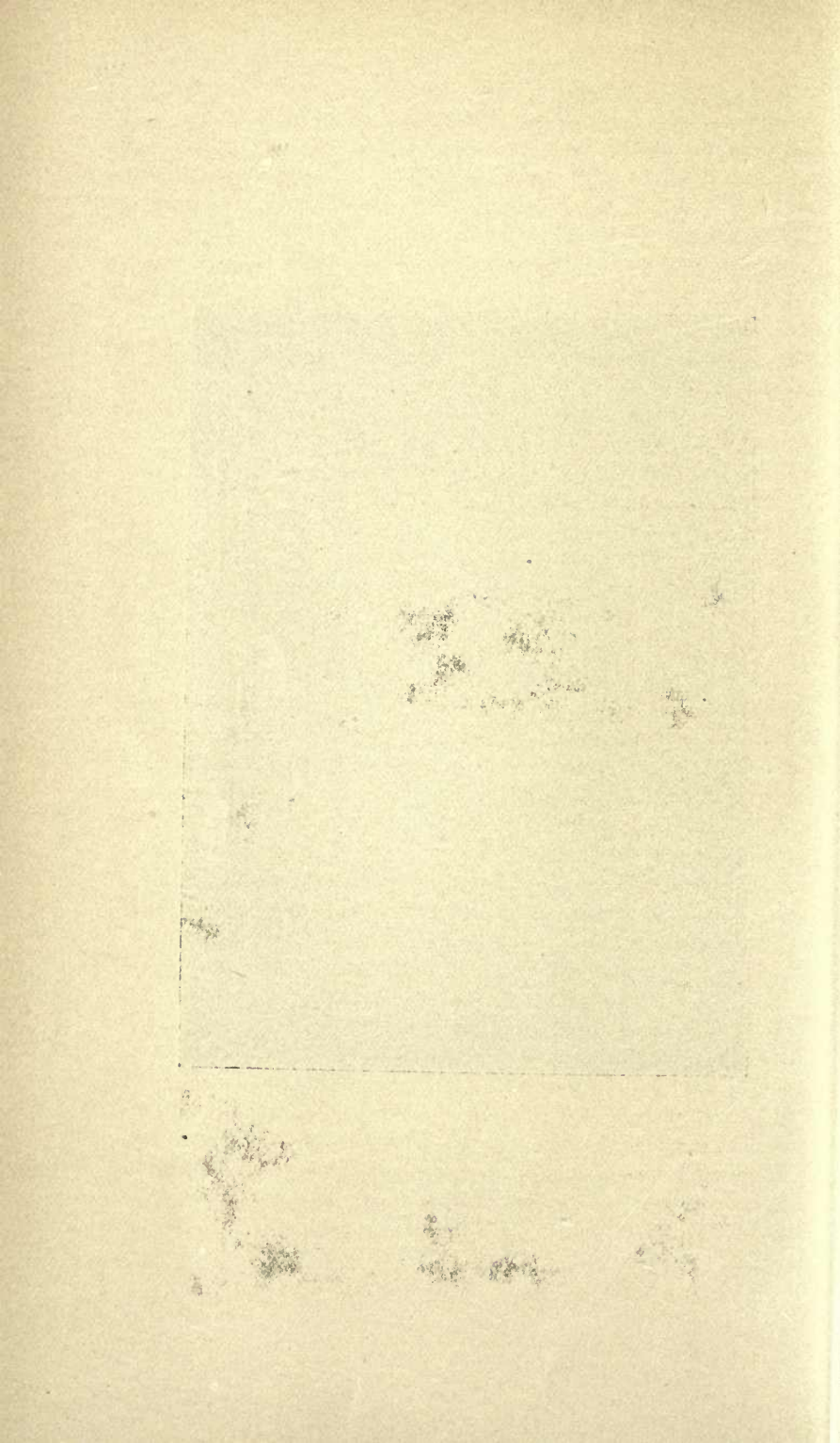

The steel straight-edge is $5\frac{1}{2}$ -ft. in length, $2\frac{1}{2}$ -ins. in depth, $\frac{3}{8}$ -in. in width and is graduated so as to give the horizontal distances from the inner face of the orifice plate. The vertical ordinates are measured by a Vernier caliper specially adapted for the purpose. The flat face of the movable limb is made to rest upon the upper surface of the straight-edge, and the caliper arm hangs vertically. A bent piece of wire, with a needle-point, is clamped to the other limb, and by means of the screw adjustment, can be readily moved until it just touches the upper or lower surface of the jet.

The sectional dimensions of the jet are determined by the jet measurer.

One end of a horizontal 2-in. bar is attached to the front of the tank and the other is supported on a frame bolted to the sides of the flume. A split cross-head, or sleeve, slides along this bar and may be clamped by a tightening screw in any desired position. Upon the cross-head there is another split boss, or sleeve, through which a second bar passes at right angles to the first, and carries a similar cross-head to that on the 2-in. bar, so that provision is made for a rough adjustment in a vertical plane. Through the latter cross-head passes a smaller bar, and along this bar slides a third adjustable cross-head, or caliper-holder, by which the caliper can be swung round and receive its final adjustment. For the measurements a 12-inch Brown & Sharpe Vernier caliper is used. A capstan head rod is clamped to each leg and can be swivelled through any angle. Steel needle pointers are inserted in the heads, and are clamped in such position as may be required. In making a measurement the steel points are first made to touch and the corresponding readings taken. The points are then separated by sliding the caliper heads apart, and the whole apparatus is moved into position. The points are finally adjusted so as to touch the surfaces of the jet at opposite points, and readings are again taken. From the two sets of readings the transverse dimension of the jet can be at once determined.

With this apparatus, jet measurements can be made to the one-thousandth of an inch, and at any point between 72 inches and $\frac{1}{8}$ -in. from the inner edge of the orifice plate, but rigidity is most essential.

Impact Apparatus.—This apparatus was constructed for the purpose of determining the force with which jets from orifices, nozzles, etc., impinge upon veins of different forms and sizes. (See Fig. 1, p. 1.)

A massive cast-iron bracket, 8-ft in length, has one end securely bolted to the front of the tank, and the other supported by a vertical tie-

rod from one of the oak beams in the ceiling. The upper surface is provided with accurately planed slides, which are set level about 5-ft. above the orifice axis. If, from any cause, the end of the bracket farthest from the tank is found to be too high or too low, the error can be corrected by loosening or tightening the nut on the tie-rod.

The balance proper is carried by a sliding frame which can be moved horizontally into any position along the bracket by means of a rack and pinion actuated by a sprocket wheel with chain. At one end the frame has two equal arms with a common horizontal axis parallel to the bracket, and each arm has a stop on its lower surface which serves to limit the oscillation of the balance.

The balance, in its mean position, consists of a main trunk with horizontal axis rigidly connected with a vertical slotted arm and with two equal horizontal arms at one end. The common axis of the latter is horizontal and perpendicular to the axis of the main trunk. The hardened steel knife edges of the balance are 4-ft. centre to centre and rest in hardened steel Vees inserted in the ends of the sliding frame on each side of the bracket. The bottom of each Vee is in the same horizontal line (called the axis of the Vees) at right angles to the bracket.

A bar with the upper portion graduated in inches and tenths has a slot in the lower portion, which is bent into a circular segment of $9\frac{1}{2}$ -ins. radius. The bar slides along the slot in the vertical arm of the balance. A radial block, with the holder into which the several vanes are screwed, moves along the slot in the circular segment, and may be clamped in any required position, the angular deviations from the vertical being shown by graduations on the segment. The centre of this segment in every case coincides with the central point of impact on a vane, is in the vertical axis of the balance arm and is also vertically below the axis of the Vees. Thus the jet can always be made to strike the vane both centrally and normally.

The scale pan hangs from a knife-edge at one end of the horizontal arms of the balance, while to the other end is attached a fine pointer, which indicates the angular movement of the balance on a graduated arc fixed to the sliding frame. The balance is in its mid-position when the pointer is opposite the zero mark.

When a vane has been secured in any given position, the preliminary adjustment of the balance is effected by moving a heavy cast iron disc along a horizontal screw fixed into the main trunk. The sensitiveness of the balance is also increased or diminished by raising or lowering heavy weights on two vertical screws in the top of the trunk.

Assume that the adjustments have all been made and that the jet now impinges normally upon a vane.

Let W be the weight required in the scale pan to bring the balance back into its mid-position.

Let F_a be the *actual* force of impact determined by the balance.

Let F_t be the *theoretical* force of impact deduced by the ordinary formulæ.

Then the ratio $\frac{F_a}{F_t} = c_i$ may be called the co-efficient of impact.

Let y be the vertical distance of the central point of impact below the horizontal axis of the orifice, which is 36 ins. below the axis of the Vees. The distance between this axis and the point of suspension of the scale-pan is 24 ins.

Let ϕ be the angle through which the water is turned on the vane.

Let θ be the angle which the tangent to the path of the jet at the point of impact makes with the horizontal.

Let h be the head over an orifice of sectional area A .

Then,

$$F_a \cos \theta (36 + y) = W 24$$

and

$$\begin{aligned} F_t \cos \theta &= 2 w c_c c_v^2 A h (1 - \cos \phi) \\ &= 2 w c_d c_v A h (1 - \cos \phi) \\ &= 4 w c_d c_v A h \sin^2 \frac{\phi}{2} \end{aligned}$$

w being the specific weight of the water and c_c , c_v and c_d the co-efficients of contraction, velocity and discharge, respectively.

Thus c_i the co-efficient of impact

$$= \frac{F_a}{F_t} = \frac{6 W}{w c_d c_v A h \sin^2 \frac{\phi}{2} (36 + y)}$$

For a flat vane and taking $w = 62\frac{1}{2}$ lbs. per cub. feet,

$$c_i = \frac{.192 W}{c_d c_v A h (36 + y)}$$

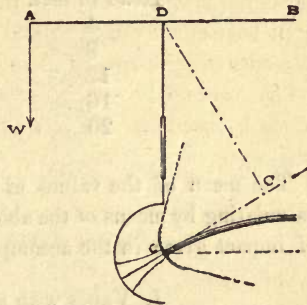

DIAGRAM
IMPACT BALANCE

A very few co-efficient of velocity (c) experiments gave the following results :

Head in feet.	Co-efficient of velocity (c_v)
4	.9950
8	.9960
12	.9957
16	.9960
20	.9954

The mean of the values of c_v , namely .9956, is the value used in calculating by means of the above formula, the values of the co-efficient of impact given in the accompanying table:

I. Vanes with smooth polished surfaces.

Form of Vane	Surface area in sq. ft.	Head over orifice in ft.	Co-efficient of impact (c_i) diar. of orifice being		
			.5-in.	.6769 in.	1.0002 in.
Flat	.0491	4	.9691		
"	"	8	.9684		
"	"	12	.9725		
"	"	16	.9749		
"	"	20	.9767	.9777	.9723
Circular segment					
of 135°	.0575	4	.9048		
"	"	8	.9189		
"	"	12	.9319		
"	"	16	.9360		
"	"	20	.9377	.9677	.9777
Circular segment					
of 150°	.0654	4	.8789		
"	"	8	.8969		
"	"	12	.9004		
"	"	16	.9036		
"	"	20	.9068	.9520	.9561
Circular segment					
of 165°	.0780	4	.8668		
"	"	8	.8877		
"	"	12	.8955		
"	"	16	.8982		
"	"	20	.8861	.9360	.9560

Form of Vane	Surface area in sq. ft.	Head over orifice in ft.	Co-efficient of impact (c		
			diar. of orifice being .5-in.	.6769 in.	1.0002 in.

Circular segment

of 180°	.0982	4	.8297		
"	"	8	.8454		
"	"	12	.8544		
"	"	16	.8572		
"	"	20	.8623	.9219	.9685

II. Vanes with surfaces rough as cast.

Flat	.0491	4	1.0168		
"	"	8	1.0276		
"	"	12	1.0343		
"	"	16	1.0411		
"	"	20	1.038	1.0295	1.0179

Circular segment

of 180°	.0982	4	.7447		
"	"	8	.7527		
"	"	12	.7570		
"	"	16	.7593		
"	"	20	.7567	.8467	.9203

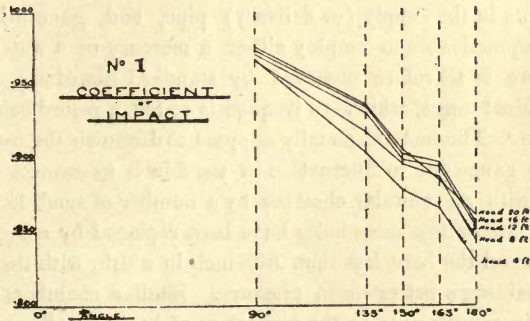

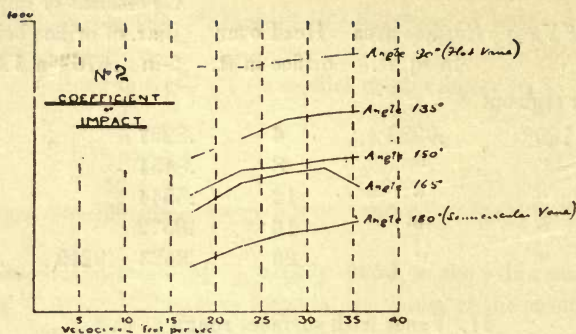

In the above diagrams, fig. 1 represents the variation of the c_i for different angles of deflection.

The results obtained for each head or velocity are combined into a curve.

The angle of deflection denotes the total angle through which the direction of motion of the water is turned, i.e., 90° for a flat vane ; 180° for a hemispherical vane.

Fig. 2 shows the variation of the coefficient c_i with the head or velocity of the impinging stream. The curve indicates the value for each angle of deflection. The general indication of the curves is that the co-efficient increases with the velocity.

The Testing of Motors, Gauges and Pressure Chamber. In motor testing it is of importance to know the pressure of the water at certain points in the supply (or delivery) pipe, and, generally speaking, it is impracticable to employ either a mercury or a water gauge. The pressure is therefore observed by standard Bourdon gauges, of small individual range, which are frequently tested, a record being made of the errors. The method usually adopted to diminish the oscillating effect in the gauge due to fluctuation in the flow is to connect the bore of the pipe with an annular chamber by a number of small holes. In the McGill Laboratory these holes have been replaced by a continuous opening around the bore, less than .005 inch in width, with the obvious result of obtaining a better mean pressure. Similar chambers are also being used in experiments on the resistance of bends to flow. There are four sets of bends of 1 in., $1\frac{1}{2}$ in., 2 in. and 3 in. diar., and each set consists of 30 bends, 10 having a radius of *one* diameter, 10 of *two*

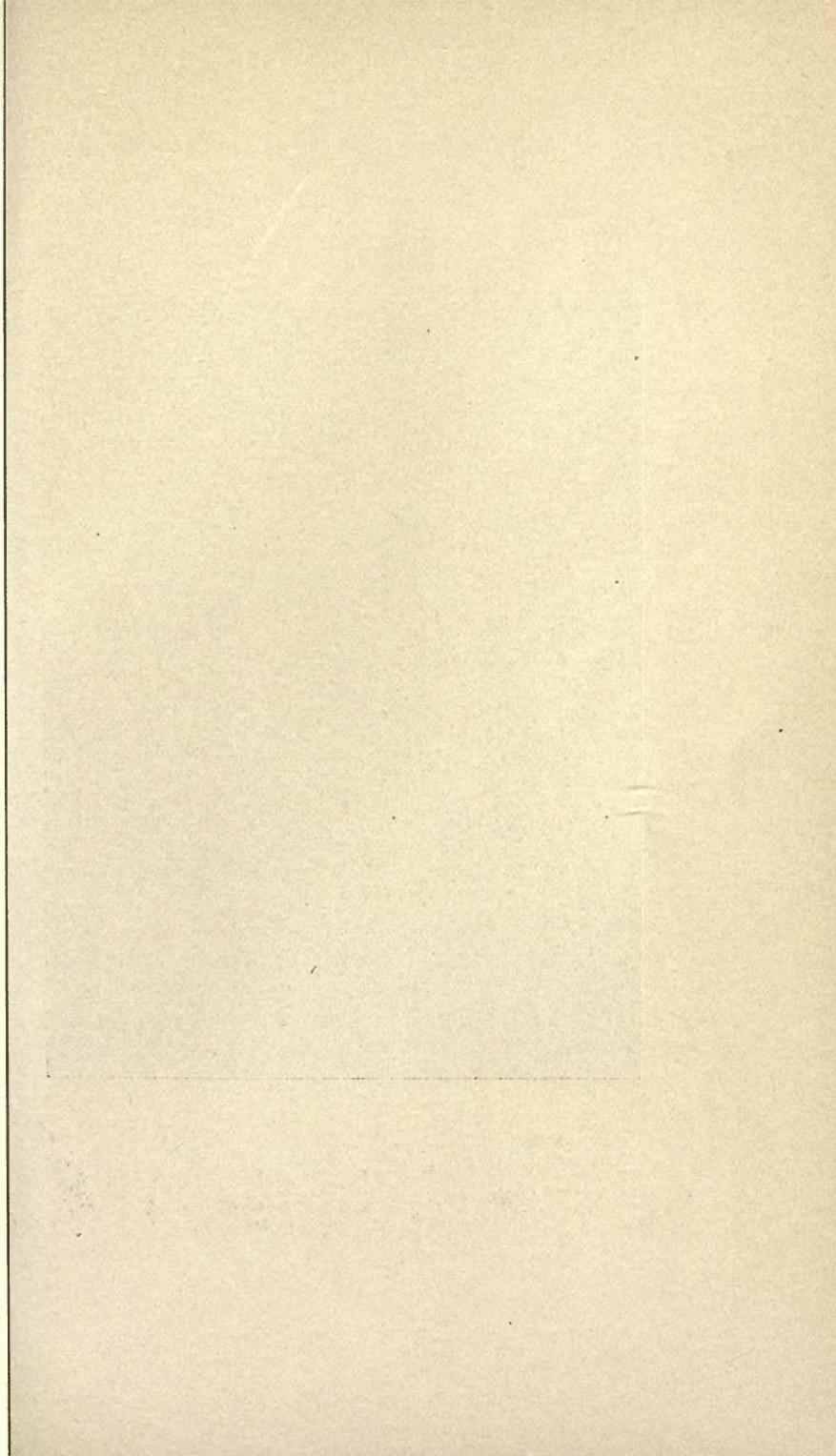

10

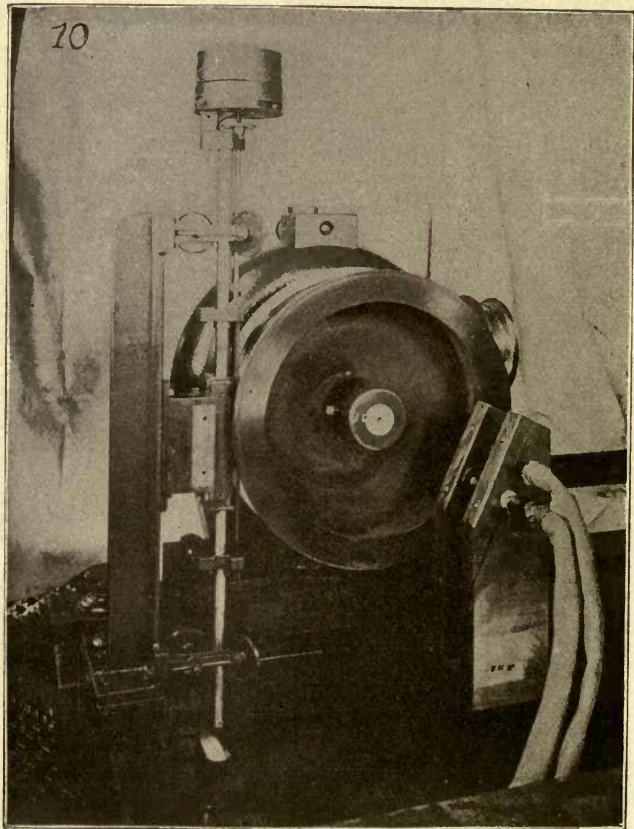

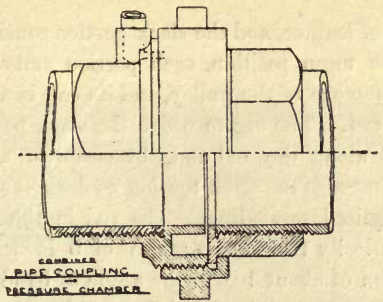

diameters and 10 of four diameters. At the central cross-section of each bend, provision is also made for ascertaining the pressure, either by a mercury column or by a gauge, at the extremities of the radii to the outer and inner surfaces of the bore. The chambers for the bends are combined with union couplings, of the same bore, which allow the attached part to be swivelled through any required angle.

Speed Indicators.—The speed of the motor is taken by a revolution counter and also by a tachometer. A sliding slotted sleeve at one end of main shaft of the motor can be made to engage with the spindle of the revolution counter, which can therefore be readily thrown in and out of gear at the commencement and end of a test, and the readings can be taken at leisure. The tachometer is supported on a bracket fixed to the motor frame, and is driven by a cord passing over a pulley on the motor shaft.

Brake.—Besides a Halpin brake of 50 H.P. capacity, the laboratory is equipped with a friction brake which has been designed by Mr. Withycombe, the superintendent, and which can be used with wheels both of the horizontal and the vertical type. It possesses many novel features of which the most important are :—

First, that it is self-adjusting and

Second, that a single direct weighing gives the total drag.

The brake wheel is of cast-iron and turned inside and out. The outer and inner surfaces of the rim are shrouded, the shrouding on one side being formed by the solid disc connecting the rim with the boss. A stream of water is delivered tangentially into the channel inside the wheel through a narrow rectangular mouthpiece of nearly the same width as the channel. The surplus water is carried away by a scoop of somewhat similar form but reverse in action. The tight portion of

the brake band is of leather, and the slack portion consists of two strips of copper. In the mean position, each portion embraces about one-half of the circumference of the pulley, and its end is attached to a lug projecting from a rod. The lug to which the slack portion is joined is capable of sliding along the rod and, by means of a screw, can be adjusted so as to increase the slack tension as desired and therefore to produce any required total drag. The rod in the direction of its length has a practically frictionless range of 5 inches, which corresponds to a variation of about 16° in the angle of band contact. The resultant force along the rod is the difference between the tight and slack tensions, and measures the drag. The force is balanced by dead weights which are placed in a tray at the top of the rod for a vertical wheel and, if the wheel is horizontal, in a scale-pan suspended by a cord which passes over a frictionless pulley and is attached to the head on the rod.

If, from some cause, the band friction should increase, the drag would also increase, and there would be a corresponding movement of the rod. Thus, a portion of the leather band would be unwrapped, while an equal portion of the copper band would be brought into contact. But the frictional co-efficient for leather exceeds that for copper, so that the drag would be less and would continue to diminish until it again balanced the weight. The reverse, of course, would be true, if the band-friction should diminish. The rod would move in the opposite direction, an excess of the leather band would be brought into contact and the drag would continually increase until equilibrium was again restored.

Hence, within a certain range, the band will find a position of equilibrium, although the friction may vary, and the total drag will then be measured by the dead weight in the tray or in the scale-pan.

If the movement of the rod should be so great that it may come against one of the stops provided to limit its action, the drag can be re-adjusted by means of the screw attachment. This, however, is very unlikely to happen, as the range already allowed is sufficient to admit of a large variation in the value of the co-efficient of friction. It has been found that the best results are obtained by running the wheel without any lubricant on the rim; care should be taken to protect the rim from water or oil, which would necessarily produce a considerable variation in the frictional resistance.

This brake has been in use only a few months, but in the several trials which have been made it has fully realized the expectations that

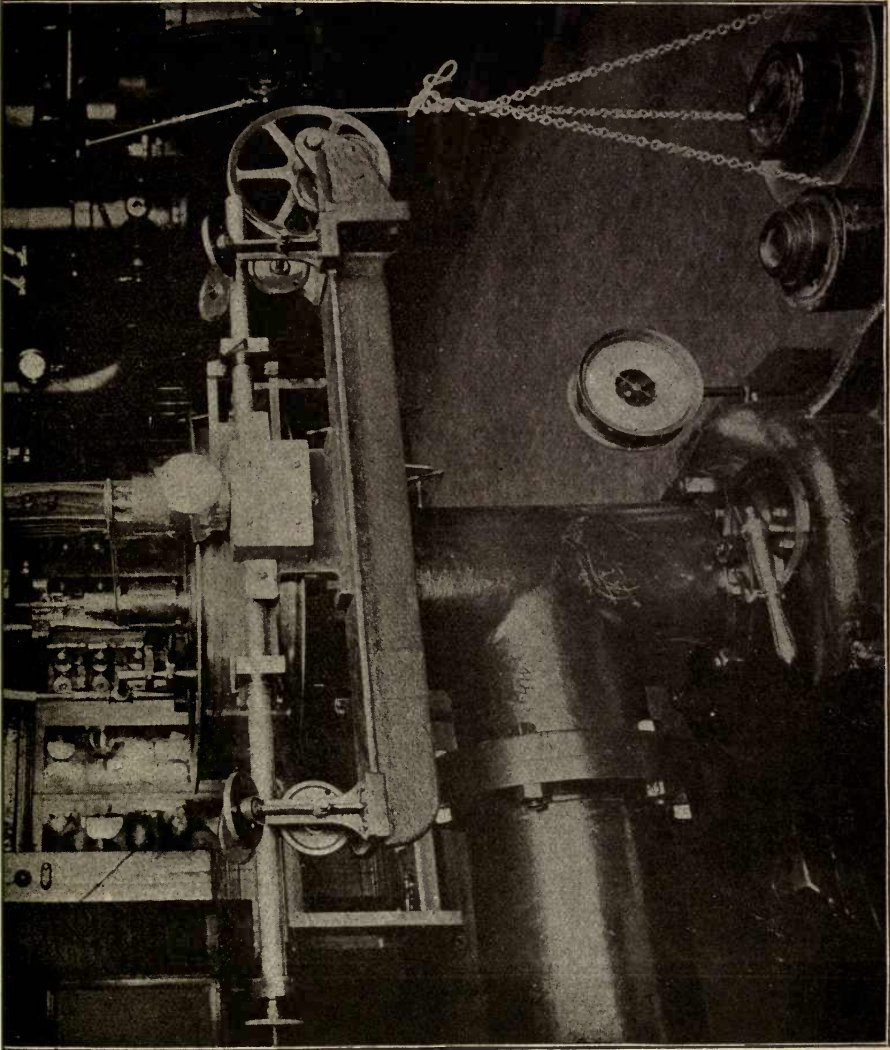

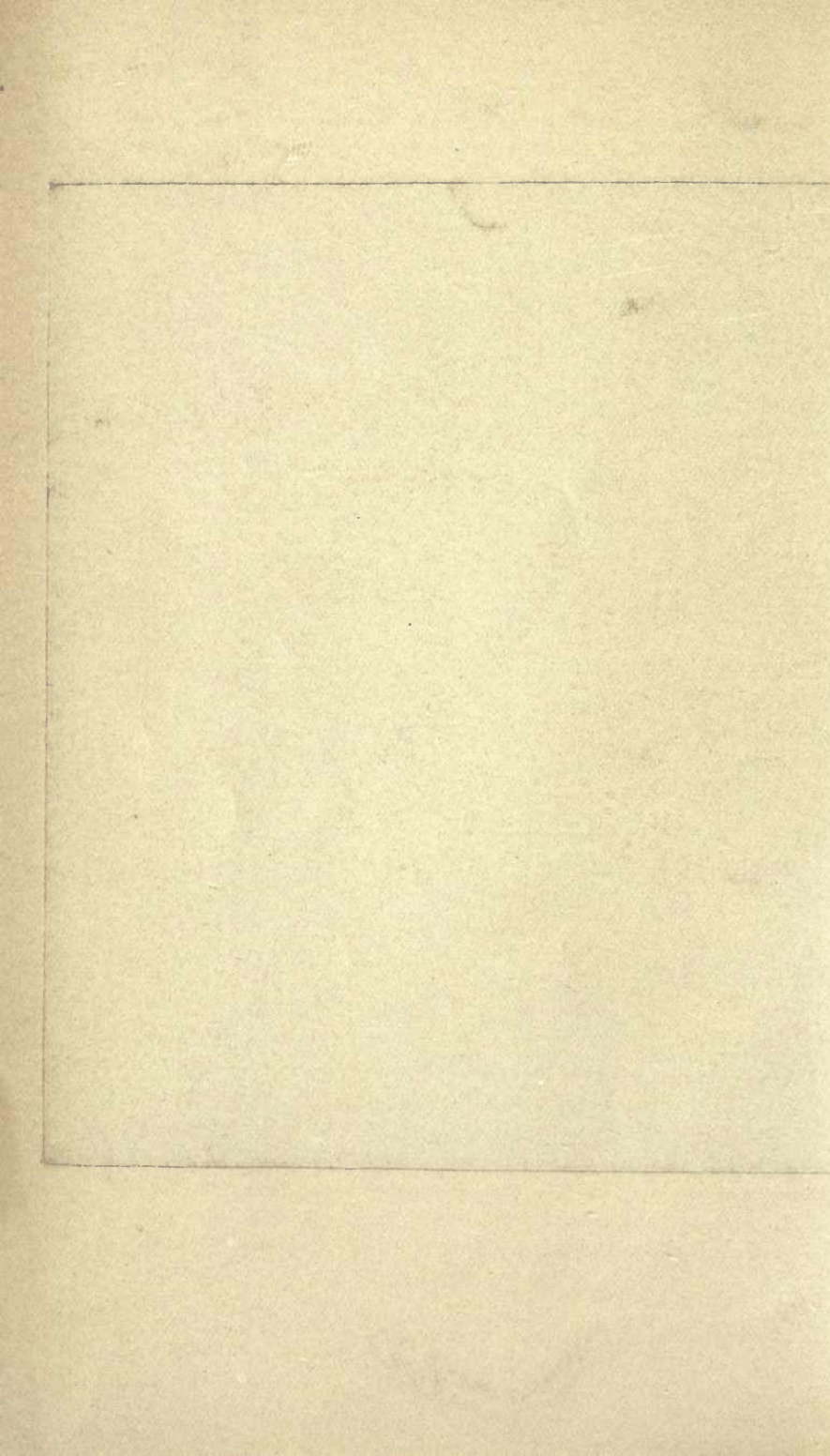

had been formed of its efficiency. It has been employed in measuring directly off the jack shaft the power developed by a 6 in. turbine with vertical axis and a 16 in. Pelton wheel with horizontal axis.

It may be noted that the weight of the rod and connected parts has been made exactly 10 lbs., which, of course, forms part of the dead weight in the case of a vertical wheel.

Measurement of Water.—The whole of the water is discharged into the flume, and passes over the weir into the large calibrated tanks. If the quantity is too great to be measured in the tanks, the water is run to waste and the discharge calculated from the normal weir formula. Co-efficients of discharge have been found for various depths over the lip, and the co-efficient for any particular depth can be very approximately determined by interpolation. The depth over the lip is obtained by means of the "depthing" apparatus, which consists of a deep girder stretching across the flume and carrying three hook gauges with Verniers which read to .001 inch.

Centrifugal Pump.—The Centrifugal Pump is erected over the flume in a framework which allows it to be raised or lowered so that the heights of suction and discharge may be varied at will. For this purpose the piping is made in interchangeable lengths of 2 feet. The pump is driven by a 9 inch belt and discharges into the ceiling circuit already described. From this circuit the water is delivered into the top of the Experimental Tank, flows into the adjoining flume, passes over an intercepting weir for calibration and is then again conveyed along the flume to the pump. Thus, the same water can be used over and over again.

Turbine Tester.—The turbine is supported upon an annular flange bolted to the bottom of a cast-iron cylinder. An 8-inch tee is secured to the crown of the cylinder, and a cover with a specially designed gland is bolted to the upper flange of the tee. The jack-shaft passes through this gland, which forms an almost frictionless bearing. No packing is required, as provision has been made for carrying away any slight leakage that might occur. The jack-shaft passes through a piece of pipe screwed to the bottom of the cover and extending downwards to the cylinder, so that it is protected from the impulsive effect of the inflowing water. The supply pipe is connected with the horizontal branch of the tee, and the entrance of the water is controlled by an 8 inch straight-way valve placed at some distance from the opening.

The gates of the turbine, for example, one of the New American inward and downward flow type, are worked by means of a shaft ex-

tending from a pinion geared to the toothed quadrant and passing through a gland in the crown of the cylinder. The upper end of the shaft is provided with a handle and pointer, which indicates on a graduated quadrant the extent of the gate opening.

Suitable pressure gauge connections have been arranged in the upper and lower parts of the cylinder.

The power of the turbine is determined by the friction-brake already described.

Experimental Pump.—This pump is of the vertical triple throw single acting plunger type, and is driven by two 10 inch double leather belts running on 48 inch pulleys formed on the outer cranks, or discs. The plungers are 7 ins. in diameter and have an 18 inch stroke. The approximate maximum delivery is estimated to be 1,000 gallons per minute when the pump is running at a speed of 150 revolutions per minute against a pressure of 120 lbs. per sq. inch. The suction valve chambers are placed directly over the calibrating tank nearest the east wall, and draw the water from this tank through two 10-inch suction pipes. Each discharge valve chamber is directly connected with a 12 inch header, which discharges into the 8 inch ceiling circuit. The water may be made to flow in almost a direct line to the point of discharge, or it may be made to pass around the three sides of a rectangle so that the effect of the additional bends and increased length of piping may be estimated. The water flows into the experimental tank at a point 20 feet above the level of the discharge valves.

One of the features of the pump is the provision made that the valves can be taken out and replaced by others of a different type. The valves at present in situ are a Riedler valve and two others with groups of 36 circular disc valves of $1\frac{5}{8}$ inches diameter in each.

In addition to the usual pressure gauges, tachometer and revolution counter, the pump is fitted with a specially designed continuous triple indicator apparatus, which autographically records during any given time of a trial the speed, variation and duration of the valve chamber pressure at any point of the stroke. Sight holes are provided for observing the movement of the valves and indicators for recording their lift. A special recording gauge also registers the pressure in the delivery pipe.

As the pump is for experimental work, it has been made unusually heavy, its total weight being about 55,000 lbs. The plungers, valves and valve seats, all internal screws, nuts, etc., are of bronze, and weigh more than 3,700 lbs.

UNIVERSITY OF CALIFORNIA LIBRARY
BERKELEY

Return to desk from which borrowed.
This book is DUE on the last date stamped below.

26 Oct 50GE

LD 21-100m-11,'49(B7146s16)476

YH 02449

662531

TAI
MR

no. 1-4

UNIVERSITY OF CALIFORNIA LIBRARY

Row 2-1